

iAM MIX-16



Multi-Channel Audio Monitoring & Metering of IP and Baseband Signals



Intuitive monitoring and mixing of audio from multiple sources, with browser-based user interface and API's



The iAM Command & Control Interface

Wohler Technologies has been in business for over 30 years. We invented in-rack monitoring and we are now RE-INVENTING this broadcast technology for the modern media enterprise to handle IP MONITORING.

Flexible. Adaptable. Future Proof.

Specifically designed for fast-paced OB, studio and live-to-air production environments, iAM-MIX provides intuitive audio signal monitoring with instant access to signals or to user-definable presets of any individual signal source or a mix of sources for monitoring and mixing. **Signal options include the latest IP formats: SMPTE 2110, SMPTE 2022, Ravenna™/AES67 and Dante™**

Choose from either 8 or 16 level controls, both with an independent master level control and instant mute capability and push-for-solo capability. Individual OLED display indicators show status, presence metering and channel name – which can be manually edited or automatically read from a network connected router.

Multiple units on the same network can be controlled via a browser-based user interface that supports fast configuration with role-based authentication to protect critical setups. In short, iAM-MIX is the perfect solution for any application that requires a simple, compact solution for monitoring a range of audio signals.

Features/Benefits:

- Fast selection and summing of up to 8 audio channels, allowing quick muting and hold-for-solo
- Master volume control that also provides a master mute/unmute
- Channel names can be displayed for each input or pulled from a router
- Built-in speakers, headphone jack, USB and Ethernet ports
- A range of included and optional connectors and signal processing options, including SFP slots for future I/O and Ethernet inputs for IP-based I/O
- Store and retrieve up to 64 presets (8 accessible on front panel)
- Software upgradeable via USB or network, upgrade multiple units at once
- APIs for remote control

Model	Part ID		Description
iAM-Mix8	8114-0090	Base Unit	1RU Base unit, includes Analog as standard
iAM-Mix16	8114-0140	Base Unit	1RU Base unit, includes Analog as standard
SFP-2110 w/Ember+	829086	I/O Option	Receiver; Multi-Mode 850 NM, LC Connectors
SFP-2110 w/NMOS	829086-1	I/O Option	Receiver; Multi-Mode 850 NM, LC Connectors
SFP-2022	829088	I/O Option	Receiver; LC Connectors
SFP-2110 w/Ember+ +2022-6	829087	I/O Option	Either-Or; Multi-Mode 850 NM, LC Connectors
SFP-2110 w/NMOS +2022-6	829087-1	I/O Option	Either-Or; Multi-Mode 850 NM, LC Connectors
SFP-SDI	829089	I/O Option	3G/HD/SD-SDI single video receiver w/ active loopback, HD-BNC
SFP-SDI-Fiber	829084	I/O Option	3G/HD/SD-SDI or ASI single receiver w/ active loopback, HD-BNC
OPT-AES	829080	I/O Option	Enables decoding and monitoring of 4 x AES inputs, 1 AES Output
OPT-MADI	829092	I/O Option	Enables decoding and monitoring of 1 x MADI64 input via BNC
SFP-MM-MADI-FIBER	829081	I/O Option	MADI fiber transceiver, Multimode; LC Connectors
SFP-SM-MADI-FIBER	829082	I/O Option	MADI fiber transceiver, Single mode; LC Connectors
OPT-DANTE	829078	Processing Option	Enables decoding and monitoring of Dante™ input streams
OPT-RAVENNA 256	829079	Processing Option	Enables monitoring of up to 256 ch Ravenna™ / AES67 Input. NMOS support
OPT-RAVENNA 64	829173	Processing Option	Enables monitoring of up to 64 ch Ravenna™ / AES67 Input. NMOS support
OPT-OUTPUT-ROUTING	829159	Processing Option	Enables the flexibility to route input signals to various outputs.

iAM MIX-16



Multi-Channel Audio Monitoring & Metering of IP and Baseband Signals

Rear Panel

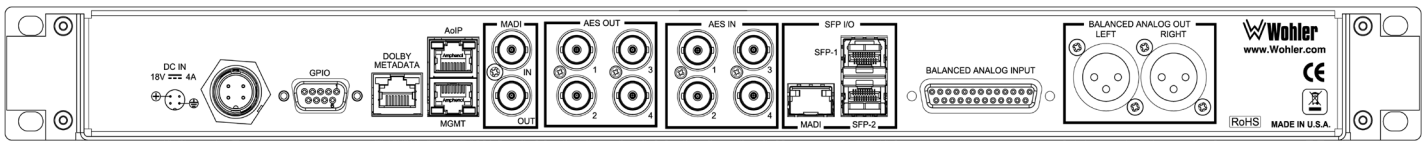

Block Diagram

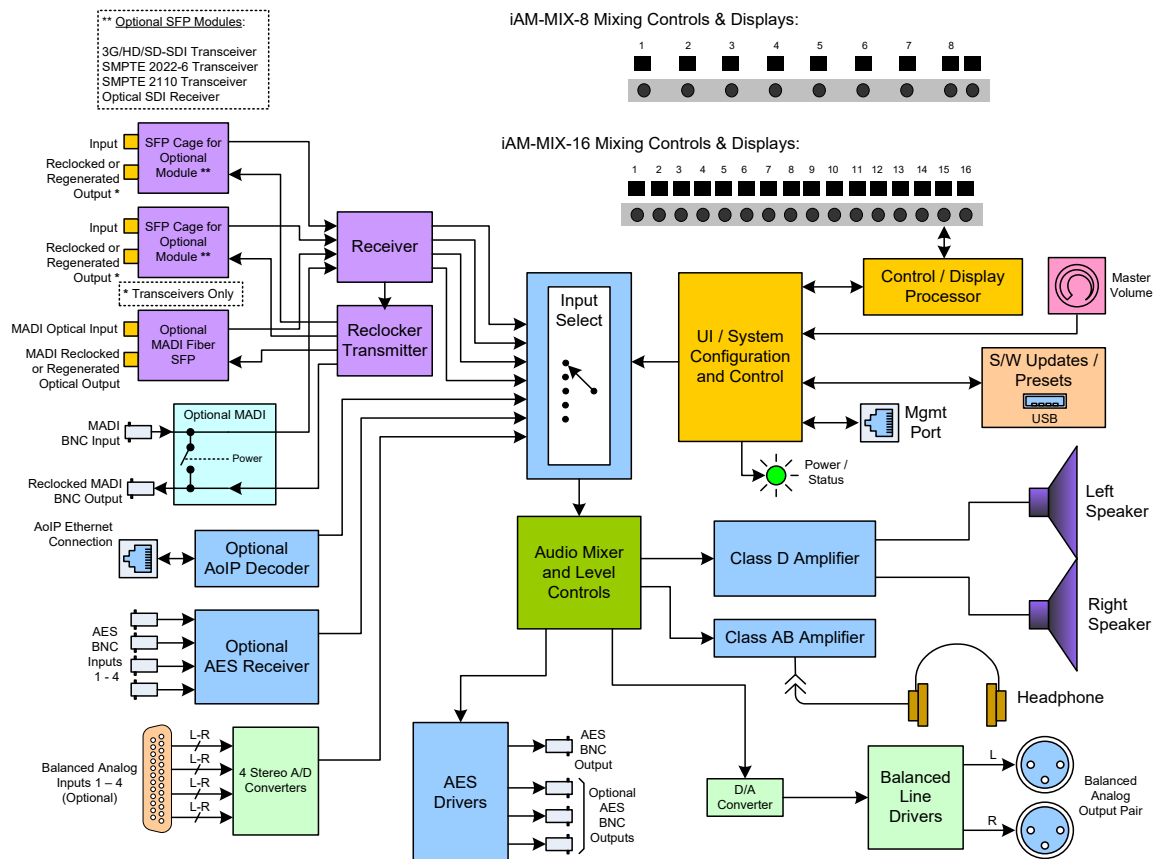

Specifications	iAM-MIX-8 / iAM-MIX-16
Height	1RU
Dimensions	19" x 1.75" x 6.5" (483 x 44 x 165 mm)
Shipping / Net Weight	8.5 lbs (3.9 kg) / 6.5 lbs (2.9 kg)
Power Supply	External: 18 VDC from 100 - 240 VAC ± 10%, 50/60 Hz, CE & UL approved
Power Consumption	40W typical
Display Type	Passive Matrix OLED x 9 / x 16
Audio Channel	8 Max / 16 Max
Frequency Response	150 Hz to 16 kHz (± 5 dB) acoustic, 40 Hz to 20 kHz (± 1dB) electrical
Peak Acoustic Output	90 dB SPL @ 2ft
Speaker Power Output	RMS Each Side: 4W Continuous /8W Peak
Upgrades	Via USB or GUI software & Ethernet; Upgrading multiple units available via web interface
Presets	iAM-Mix 8 * 8 / iAM-Mix-16 *16 programmable/nameable. Can be copied from unit to unit via USB or GUI software and Ethernet
Router Integrations	Units support Evertz, Grass Valley & Tallyman protocols for automated display of channel labels
Available APIs	Get Available Presets; Get Preset Information; Get Active Preset; Apply Preset; Set Mute/Unmute Channel; Set Solo Channel; Source Select

三友株式会社

東京本社 〒141-0022 東京都品川区東五反田1-2-33 白雉子ビル9F

代表 TEL 03-6408-1450 / FAX 03-3440-7755

NHK営業事業部 03-3463-1608 / 関東営業所 029-851-0591 / 勝田オフィス 029-264-2486

/ 大阪営業所 06-6452-4501 / 九州営業所 092-282-3622 / 大分営業所 097-567-3227